



SC240-MP

SMART I/O™

Multi-Protocol Controller
(NATIVE BACnet®, LonTalk®)

DESCRIPTION

Setting a NEW Standard in the industry, only one controller is needed to satisfy today's Building Automation protocols. Smart Controls' new MP series controllers can connect to NATIVE BACnet and LonTalk simultaneously.

The Smart I/O SC240-MP breaks the multi-protocol communication barrier by providing NATIVE BACnet, and LonTalk communication all in one controller. BACnet can communicate over an RS-485 communication channel while BACnet/Free Topology and LonTalk/FT (Free Topology) are communicating over a TP/FT-10 communication channel simultaneously to provide monitoring, control and diagnostic information.

In addition, the SC240-MP has the capability to communicate BACnet/IP or LonTalk/IP in a manner that is transparent to both the application and FT network. With BACnet/IP, applications on the SC240-MP run unmodified over a very reliable Free Topology channel delivering BACnet Objects. With LonTalk/IP, applications on the SC240-MP run unmodified over the same reliable Free Topology channel delivering network and configuration variables. The IP address is established at the device level. The SC240-MP is fully compatible and discoverable using industry standard, BTL certified, BACnet management clients and LONWORKS® network management software.

The SC240-MP is a fully programmable controller with 24 channels of cost effective analog and digital I/O with a real time clock allowing a complete sequence of customized operations for today's ever-changing control strategies that are required to meet continued energy efficiency requirements. The reliable cost effective I/O is continuously monitored and precisely controlled by an on-board 32-bit microprocessor.

The I/O of the SC240-MP makes it perfect for a variety of equipment control applications. The wide operating temperature range, -20 to 70 °C, makes the SC240-MP well suited for many demanding applications.

The twelve universal inputs (UI) can be configured in a variety of ways. The controller can interface with resistive type sensors for temperature measurements. The UI's can measure voltage from humidity or other transducer readings. The UI's can input current for pressure measurements. The UI's can also be used to read digital inputs and dry contacts. With 12-bit resolution, the universal inputs are field adaptable and accurate for many types of measurements.

Terminal number three of the universal inputs provides a regulated +20 VDC to source power to current transducers for interfacing. The +20 VDC source is protected by an internal auto-resettable fuse.

The six universal outputs (UO) can be configured as Triac or 0-10 VDC outputs. The controller can use Triac outputs to provide on/off or pulsed control for controlling damper positions, valves, alarms, lights or other loads where the current does not exceed 1A at 24 VAC for each output. The 0-10 VDC output has 10 bits of resolution for accurate control of external devices.

The six dedicated digital outputs (DO) are Triac outputs for control of additional on/off or pulsed external devices where the current does not exceed 1A at 24 VAC for each output.

The SC240-MP controller is protected from reverse power supply input wiring, over-voltages, transients, and other common events that can damage unprotected inputs and outputs.

Continuing the commitment to OPEN Controls, Smart Controls controllers can be programmed by multiple software packages available in the industry. User defined algorithms and functions can be programmed using VisualControl™, NodeBuilder®, LonBuilder® or other third party LONWORKS programming tools. The application program is stored in non-volatile memory allowing the application to be retained even after loss of power. The Real Time Clock and expanded memory allow applications for data logging, scheduling and time stamp monitoring and control. The versatile I/O allows numerous applications to be developed and implemented with the SC240-MP.

The enclosure snaps securely onto a 35mm DIN-rail for quick and easy mounting. A spring-loaded locking clip allows for quick and easy removal.

The wide operating temperature range, -20 to 70 °C, makes the SC240-MP well suited for many demanding applications.

APPLICATIONS

- Air Handling Units
- Fan Coil Units
- Roof Top Units
- Heat Pumps
- VAVs
- Chillers
- Boilers
- Lighting
- Energy Management
- Refrigeration
- Custom Applications

FEATURES

- NATIVE BACnet & LonTalk Protocol Communication
- IP support of BACnet/IP & LonTalk/IP when used with a Router
- FT-10 (Free Topology) and RS-485 Communication
- 12 universal inputs with 0-5V, 0-10V, 0-20mA, thermistor or dry contact
- 6 universal outputs with Triac or 0-10V
- 6 digital outputs with Triac
- Real Time Clock with Super-Cap Backup
- FLASH Memory
- Fully programmable, Application Downloading in Field
- DIN-rail mounting
- Compact Size for Minimal Space
- 2 Year Limited Warranty

SELECTION GUIDE

Models:

SC240-MP

_____ Fully Programmable I/O Controller

SC240-MP-C

_____ Fully Programmable I/O Controller
Real Time Clock with Super Cap Back-up

SPECIFICATIONS

General

Communication: NATIVE BACnet, LonTalk FT
IP Support: BACnet/IP, LonTalk/IP over TP/FT-10 (Requires Router)
Transceiver: RS-485 (termination jumper)
 Selectable Baud Rate: 38400 default, 19200, 9600.
 TP/FT-10, Free Topology
MAC Address: Dip Switch Selectable
I/O Processor: 32-bit Microcontroller
Application Processor: Neuron® FT6050
Application Memory: 64 KB RAM
Clock: 1.0 MB External Serial FLASH
 Real Time Clock (Option C)
 Back up: Super Cap

Inputs

Number: 12
Universal: Voltage; 0-5 Volts, 0-10 Volts
 Current; 4-20 mA
 Thermistor; Type 2,3 10K ohms or 20K ohms (25°C, 77°F)
 Digital; Dry Contact, TTL
Resolution: 12-bit
Accuracy: ±1% FS (25°C, 77°F)
Protection Circuitry: Transient Over voltage, ESD

Outputs

Number: 12
6-Digital: Triac 1.0 A @ 24 VAC
 Internal Source
6-Universal: Jumper selectable
 Triac 1.0 A @ 24 VAC
 Internal Source
Analog Output: Voltage; 0-10 Volts
Resolution: 12-bit
Accuracy: ±1% FS (25°C, 77°F)
Protection Circuitry: ESD

Power

Nominal Input Voltage: 24 VAC
Input Voltage Range: 19.2-28.8 VAC
Typical Consumption: 1 VA
Maximum Consumption: 1.5 VA, does not include Triac Loading

Environmental

Operating Temperature: -20 °C to +70 °C,
 -4 °F to 158 °F
Storage Temperature: -40 °C to +70 °C,
 -40 °F to 158 °F
Relative Humidity: 5% to 95%
 (non-condensing)

+20 VDC Supply

Voltage: +20 ± 0.5 VDC
Current Continuous: 0.3A Max. (20°C, 68°F)
Fused: 0.6A trip, Auto-Reset (20°C, 68°F)

Enclosure

Dimensions: L 105 x W 86 x H 58 mm
 (4.13" x 3.39" x 2.28")
Cover: Lexan 940, UL94-V0 rated
Base: Noryl VO1550, UL94-V0 rated

DIMENSIONS

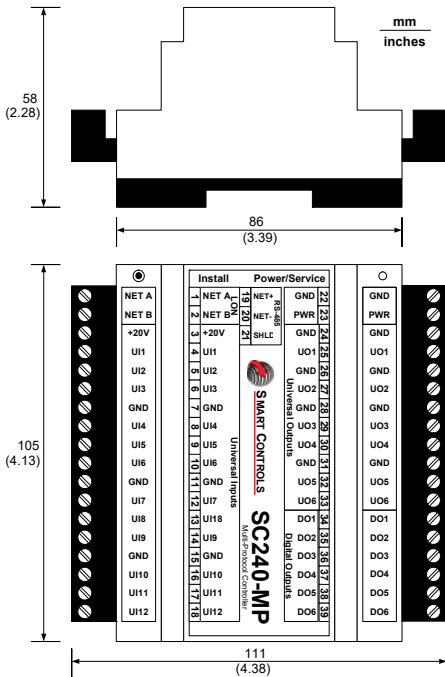

CONTACT



Office:
 10000 St. Clair Avenue
 Fairview Heights, IL 62208
 U.S.A.
 Phone: 618-394-0300
 Fax: 618-394-1575

E-mail:
sales@smartcontrols.com

Web site:
www.smartcontrols.com

BACnet® is a registered trademark of ASHRAE.
 Echelon®, LONWORKS®, LonTalk®, NodeBuilder®,
 LonBuilder®, Neuron® and LON® are registered
 trademarks of Echelon Corporation.

Smart I/O™, Smart Controls™, VisualControl™ and
 Smart Controls Logo are trademarks of Smart
 Controls, LLC. Smart Controls, LLC reserves the
 right to make changes without further notice to this
 product for improvements in design and reliability.
 Smart Controls, LLC does not assume any liability
 arising out of the application or use of this product;
 neither does it convey any license under its patent
 rights of others.

EXAMPLE WIRING DIAGRAM

All inputs are software selected for analog, digital or resistive.

IMPORTANT WIRING INFORMATION

- Secondary of Class 2 Transformer should always be earth grounded to provide reliable communication and sensor readings.
- *External fuse not supplied. Size fuse according to application load and not to exceed 5 Amps.
- Do not connect external resistor to voltage inputs to sense 4-20 mA current devices. Incorrect readings will result.

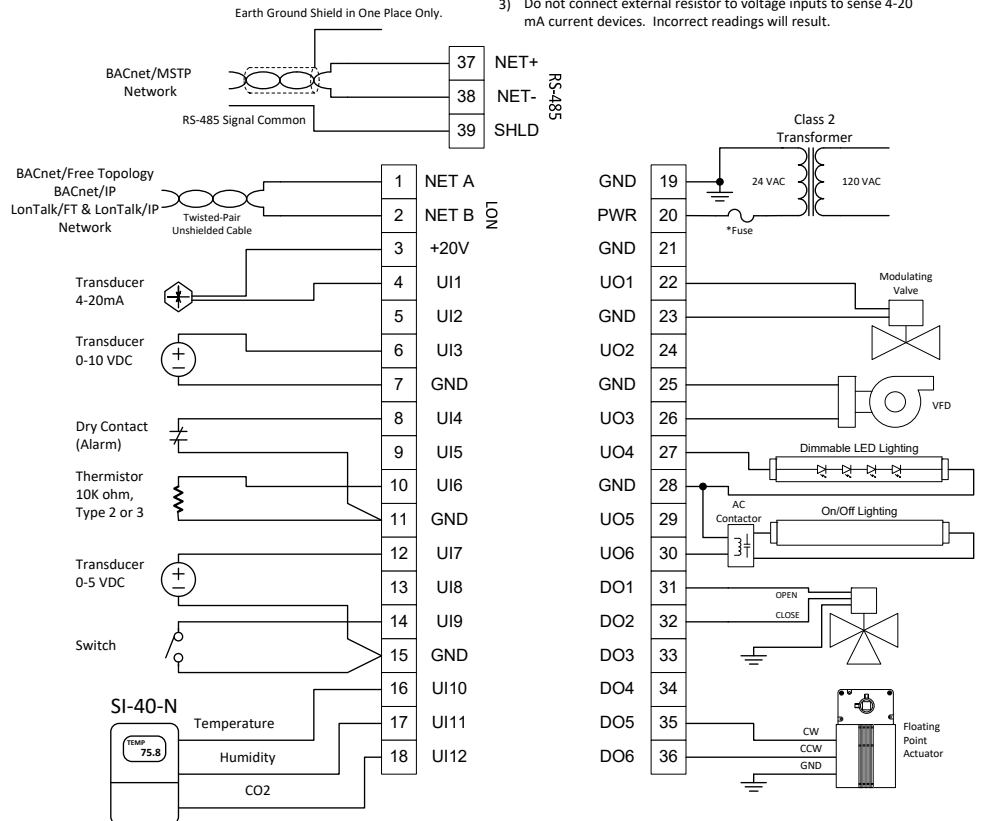

This diagram is an example of device connections and no reference to an application is being provided.